



# TUNNEL CONTINUAL WASHER

Tel: (626)823-4815 Fax: (626)698-1638

Email: sales@microwavetown.com

Web: <http://www.microwavetown.com/poultry equipments>

■ EI HATCHERY AUTOMATION



Continue tunnel industrial washer is designed for slaughter, meat processing, vegetable, fruit, and beverage and brewage etc food factory, applicable for all kinds of basket, tray, cutting board and box, Reduce water consumption up to 70% and save manpower, increase washing effect.



Inner View



High Pressure Pump



Entrance



## TUNNEL CONTINUAL WASHER

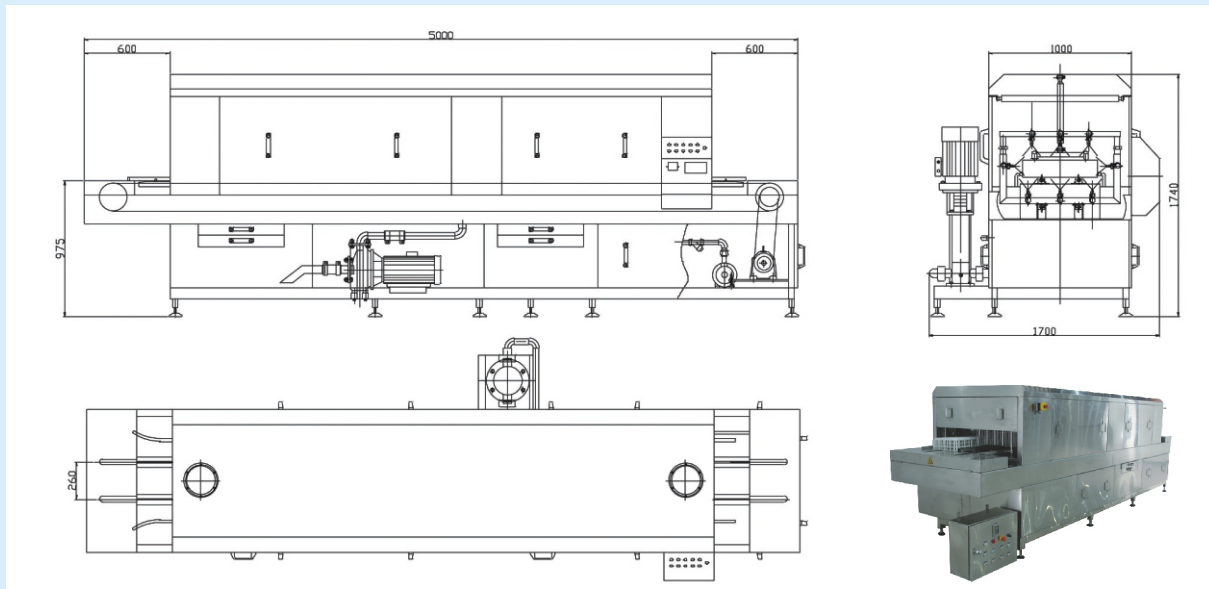

### FEATURES:

- Continue washer comprises prewashing, washing and cleaning washing three parts or chosen by customer.
- Whole heavy duty stainless steel made, good quality stainless steel water pump, washing pressure up to 3~10kg/cm<sup>2</sup>.
- Unique steam heater and temperature control in each part to insure ideal washing effect.
- Frequency control system insures freely change transfer chain speed for different requirements.
- Easy operation and saving consumption.
- Knocking down observed window at each side of tunnel, easy for maintenance.
- Imported nozzle unit, easy cleaning and adjustment.
- Filter system, easy cleaning.

### TECHNICAL DATA:

Capacity	500/h	Water Consumption	500L/h		
Speed	0.7-7m/min	Drive Power	0.37kw		
Passage Width	600mm	Passage Height	300mm		
Entrance Height	975mm				

#### PRE-RINSE UNIT

Pump Power	5.5kw	Capacity	400L/min	Pressure	3kg/cm <sup>2</sup>
------------	-------	----------	----------	----------	---------------------

#### MAINWASH UNIT

Pump Power	7.5kw	Capacity	200L/min	Pressure	10kg/cm <sup>2</sup>
------------	-------	----------	----------	----------	----------------------

#### AFTER RINSE UNIT

Pump Power	0.75kw	Capacity	8L/min	Pressure	5kg/cm <sup>2</sup>
Total Power	14.12kw				
Outside Dimension	5000×1700×1740mm				

Tel: (626)823-4815 Fax: (626)698-1638

Email: sales@microwavetown.com

Web: <http://www.microwavetown.com/poultry equipments>